

CRM-XP

4,5-150 ton
Stroke 10-15 mm
700 bar

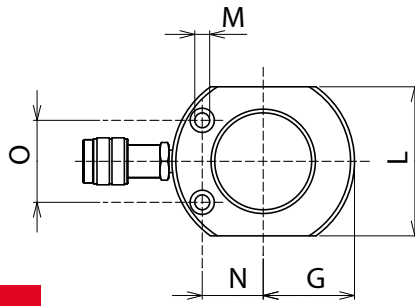

CRM-XP

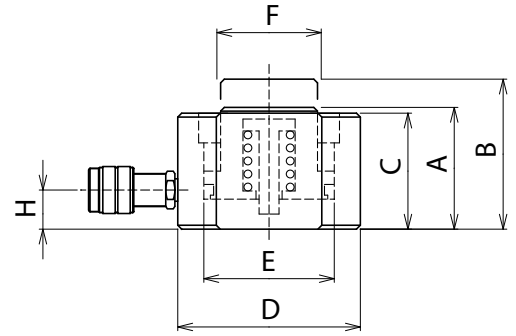

CAP/Force ton (kN)	STROKE mm	MODEL	SECTION cm ²	VOLUME cm ³	MASS kg	DIMENSIONS (mm)											
						A	B	C	D	E	F	O	H	M	N	G	L
4,5 /43,1	6	CRM-5/6-XP	6,2	3,6	1	37	43	36	59	28	24	30	18	5,5	23	23,5	45
4,5 /43,1	15	CRM-5/15-XP	6,2	9,2	1,2	46	61	45	59	28	24	30	18	5,5	23	23,5	45
10 /111,3	10	CRM-10/10-XP	15,9	15,9	1,6	50	60	49	75	45	38	40	19	6,5	28	31,5	60
20 /218,2	10	CRM-20/10-XP	31,2	31,2	3	53	63	52	101	63	50	50	19	11	40	43	86
30 /309,3	10	CRM-30/10-XP	44,2	44,2	4,2	58	68	56	117	75	60	60	20	11	45	51	102
50 /549,8	10	CRM-50/10-XP	78,5	78,5	7,4	64	74	62	147	100	80	70	22	13	58	66	130
75 /791,7	10	CRM-75/10-XP	113,1	113,1	12	70	80	68	177	120	100	90	24	13	68	81	164
100 /1077,6	10	CRM-100/10-XP	153,9	153,9	15,4	77	87	75	192	140	120	90	21	13	76	88,5	178
150 /1496,8	14	CRM-150/14-XP	213,8	299,4	29	104	118	102	227	165	130	130	25	13	80	106	215

Different strokes and tonnages available.



Series CSE TU

Super extra flat cylinders,
very high pressure –
2.000 bar

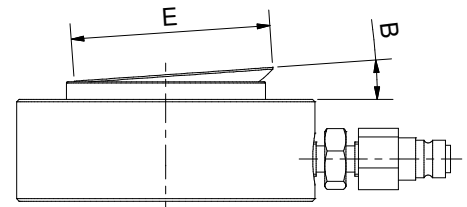
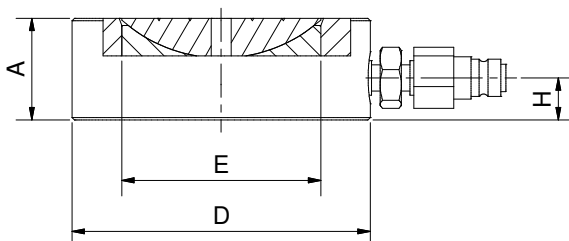

CAP/Force ton (kN)	STROKE mm	MODEL	SECTION cm ²	VOLUME cm ³	MASS kg	DIMENSIONS (mm)				
						A	B	D	E	H
100 /1005	10	CSE-100/10-TU	50,3	50	3,6	41	4°	120	80	19
200 /2077	10	CSE-200/10-TU	103,9	104	9,5	50	/	175	115	22

Super extra flat hydraulic cylinders, load return, push force from 100 to 200 tons at 2.000 bar. Used when available height is really minimal, they are suitable for working in such small spaces where it would not be possible to use the CRM XP cylinders.