

CRI GS TA

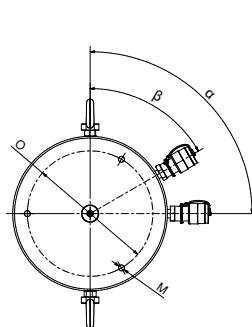

Up to 150 ton

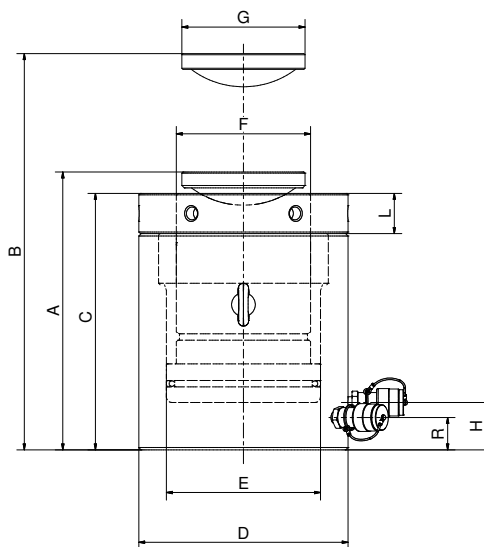
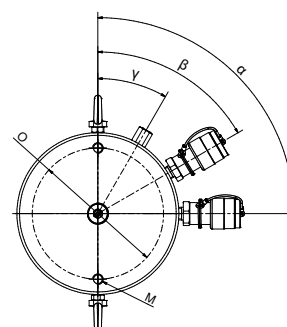

Over 150 ton

CAP/Force	STROKE	MODEL	SECTION cm ²		VOLUME		MASS	DIMENSIONS (mm)													MAX SADDLE INCLINATION		
			Push	Pull	Push	Pull		kg	A	B	C	D	E	F	G	H	L	M	O	R		Alpha (°)	Beta (°)
50 /500,30	100	CRI-50-100-GS TA	71,47	16,69	714,71	166,90	27	277	377	256	135	100	TR85X6	96	45	28	M12x1,75	105	30,8	90	60	30	5
	150	CRI-50-150-GS TA	71,47	16,69	1072,07	250,35	31	327	477	306	135	100	TR85X6	96	45	28	M12x1,75	105	30,8	90	60	30	5
	200	CRI-50-200-GS TA	71,47	16,69	1429,42	333,79	35	377	577	356	135	100	TR85X6	96	45	28	M12x1,75	105	30,8	90	60	30	5
	250	CRI-50-250-GS TA	71,47	16,69	1786,78	417,24	39,5	427	677	406	135	100	TR85X6	96	45	28	M12x1,75	105	30,8	90	60	30	5
	300	CRI-50-300-GS TA	71,47	16,69	2144,14	500,69	43,5	477	777	456	135	100	TR85X6	96	45	28	M12x1,75	105	30,8	90	60	30	5
100 /1028,09	100	CRI-100-100-GS TA	146,87	16,69	1468,69	166,90	55	299	399	275	185	140	TR120X6	116	45	38	M12x1,75	150	30,8	90	60	30	5
	150	CRI-100-150-GS TA	146,87	16,69	2203,04	250,35	63,5	349	499	325	185	140	TR120X6	116	45	38	M12x1,75	150	30,8	90	60	30	5
	200	CRI-100-200-GS TA	146,87	16,69	2937,39	333,79	76	419	619	395	185	140	TR120X6	116	45	38	M12x1,75	150	30,8	90	60	30	5
	250	CRI-100-250-GS TA	146,87	16,69	3671,74	417,24	84	469	719	445	185	140	TR120X6	116	45	38	M12x1,75	150	30,8	90	60	30	5
	300	CRI-100-300-GS TA	146,87	16,69	4406,08	500,69	92,5	519	819	495	185	140	TR120X6	116	45	38	M12x1,75	150	30,8	90	60	30	5
150 /1500,90	100	CRI-150-100-GS TA	214,41	20,62	2144,14	206,17	87,5	316	416	290	225	170	TR145X6	146	51	44	M12x1,75	185	35,5	90	60	30	5
	150	CRI-150-150-GS TA	214,41	20,62	3216,21	309,25	99,5	366	516	340	225	170	TR145X6	146	51	44	M12x1,75	185	35,5	90	60	30	5
	200	CRI-150-200-GS TA	214,41	20,62	4288,27	412,33	117	434	634	408	225	170	TR145X6	146	51	44	M12x1,75	185	35,5	90	60	30	5
	250	CRI-150-250-GS TA	214,41	20,62	5360,34	515,42	130	484	734	458	225	170	TR145X6	146	51	44	M12x1,75	185	35,5	90	60	30	5
	300	CRI-150-300-GS TA	214,41	20,62	6432,41	618,50	142,5	534	834	508	225	170	TR145X6	146	51	44	M12x1,75	185	35,5	90	60	30	5

CAP/Force	STROKE	MODEL	SECTION cm ²		VOLUME		MASS	DIMENSIONS (mm)														MAX SADDLE INCLINATION	
			Push	Pull	Push	Pull		kg	A	B	C	D	E	F	G	H	L	M	O	R	Alpha (°)		Beta (°)
200 /2002,57	100	CRI-200-100-GS TA	286,08	44,18	2860,81	441,79	134	352	452	325	265	195	TR170X6	156	60	51	M12x1,75	215	41	90	60	-	5
	150	CRI-200-150-GS TA	286,08	44,18	4291,22	662,68	151,5	402	552	375	265	195	TR170X6	156	60	51	M12x1,75	215	41	90	60	-	5
	200	CRI-200-200-GS TA	286,08	44,18	5721,63	883,57	176	469	669	442	265	195	TR170X6	156	60	51	M12x1,75	215	41	90	60	-	5
	250	CRI-200-250-GS TA	286,08	44,18	7152,03	1104,47	193	519	769	492	265	195	TR170X6	156	60	51	M12x1,75	215	41	90	60	-	5
	300	CRI-200-300-GS TA	286,08	44,18	8582,44	1325,36	210	569	869	542	265	195	TR170X6	156	60	51	M12x1,75	215	41	90	60	-	5
250 /2453,39	100	CRI-250-100-GS TA	350,48	44,18	3504,84	441,79	172	370	470	340	290	215	TR190X6	194	60	58	M12x1,75	245	41	90	60	-	5
	150	CRI-250-150-GS TA	350,48	44,18	5257,26	662,68	193	420	570	390	290	215	TR190X6	194	60	58	M12x1,75	245	41	90	60	-	5
	200	CRI-250-200-GS TA	350,48	44,18	7009,68	883,57	225	490	690	460	290	215	TR190X6	194	60	58	M12x1,75	245	41	90	60	-	5
	250	CRI-250-250-GS TA	350,48	44,18	8762,10	1104,47	246	540	790	510	290	215	TR190X6	194	60	58	M12x1,75	245	41	90	60	-	5
	300	CRI-250-300-GS TA	350,48	44,18	10514,52	1325,36	266	590	890	560	290	215	TR190X6	194	60	58	M12x1,75	245	41	90	60	-	5
300 /2948,19	100	CRI-300-100-GS TA	421,17	44,18	4211,70	441,79	206	374	474	344	315	235	TR205X6	210	60	60	M16x2	260	41	90	60	-	5
	150	CRI-300-150-GS TA	421,17	44,18	6317,55	662,68	230	424	574	394	315	235	TR205X6	210	60	60	M16x2	260	41	90	60	-	5
	200	CRI-300-200-GS TA	421,17	44,18	8423,40	883,57	268,5	496	696	466	315	235	TR205X6	210	60	60	M16x2	260	41	90	60	-	5
	250	CRI-300-250-GS TA	421,17	44,18	10529,24	1104,47	293	546	796	516	315	235	TR205X6	210	60	60	M16x2	260	41	90	60	-	5
	300	CRI-300-300-GS TA	421,17	44,18	12635,09	1325,36	318	596	896	566	315	235	TR205X6	210	60	60	M16x2	260	41	90	60	-	5
400 /4020,26	100	CRI-400-100-GS TA	574,32	75,40	5743,22	753,98	321	438	538	408	365	275	TR230X6	210	85	75	M18x2,5	280	62,5	90	60	-	5
	150	CRI-400-150-GS TA	574,32	75,40	8614,84	1130,97	352,5	488	638	458	365	275	TR230X6	210	85	75	M18x2,5	280	62,5	90	60	-	5
	200	CRI-400-200-GS TA	574,32	75,40	11486,45	1507,96	402	560	760	530	365	275	TR230X6	210	85	75	M18x2,5	280	62,5	90	60	-	5
	250	CRI-400-250-GS TA	574,32	75,40	14358,06	1884,96	433	610	860	580	365	275	TR230X6	210	85	75	M18x2,5	280	62,5	90	60	-	5
	300	CRI-400-300-GS TA	574,32	75,40	17229,67	2261,95	464	660	960	630	365	275	TR230X6	210	85	75	M18x2,5	280	62,5	90	60	-	5
500 /4976,87	100	CRI-500-100-GS TA	710,98	75,40	7109,82	753,98	406	459	559	427	400	305	TR250X6	240	85	85	M18x2,5	320	62,5	90	60	-	5
	150	CRI-500-150-GS TA	710,98	75,40	10664,73	1130,97	443	509	659	477	400	305	TR250X6	240	85	85	M18x2,5	320	62,5	90	60	-	5
	200	CRI-500-200-GS TA	710,98	75,40	14219,63	1507,96	505	584	784	552	400	305	TR250X6	240	85	85	M18x2,5	320	62,5	90	60	-	5
	250	CRI-500-250-GS TA	710,98	75,40	17774,54	1884,96	542	634	884	602	400	305	TR250X6	240	85	85	M18x2,5	320	62,5	90	60	-	5
	300	CRI-500-300-GS TA	710,98	75,40	21329,45	2261,95	579	684	984	652	400	305	TR250X6	240	85	85	M18x2,5	320	62,5	90	60	-	5